

# Etherbus<sup>®</sup> (EB Series)

Industrial Ethernet PoE Switch,  
Injectors, Splitter and More

## Hardware Guide



### Contents at a Glance:

Section 1	General Information .....	Page 3
Section 2	LED Indicators .....	Page 4
Section 3	Installation / Mounting .....	Page 6
Section 4	Power Wiring .....	Page 10
Section 5	Communication Wiring .....	Page 15
Section 6	Technical Specifications .....	Page 18
Section 7	Service Information .....	Page 22

This manual applies to the following products:

- **EB-5ES-PSE-#** Industrial PoE 5-port unmanaged Ethernet switch
- **EB-PSE-48V-2** Industrial PoE power injector for 2 channels
- **EB-PSE-24V-1** Industrial PoE power injector with built-in 24V to 48V converter
- **EB-PD-24V-1** Industrial PoE splitter converts 48V to 24V
- **EB-PD-UPS-1** Industrial PoE splitter converts 48V to 14V
- **EB-PS-4824-13** Industrial DC / DC power converter for 48V to 24V

**SIXNET Protected Technology Policy** - SIXNET protects your investment in SIXNET systems with long-term planned technology and our unique Protected Technology Policy. We will continue to support the specified capabilities of standard SIXNET products for at least five years (twenty years for Industrial Managed Switches). We plan each product improvement and new feature to be upward compatible with existing designs and installations. Our goals are to make each new software release bring new power to your SIXNET systems and have every existing feature, applications program and data file continue to work. We protect your investment even further with a liberal five-year trade-in policy. Exchange standard products for upgraded versions of the same product to take advantage of new features and improvements at any time for five years. A prorated trade-in allowance will be given for your existing unit. SIXNET protects your long-term productivity with state-of-the-art planned technology and continued support.

**SIXNET Statement of Limited Warranty** - SIXNET, manufacturer of SIXNET products, warrants to Buyer that products, except software, manufactured by SIXNET will be free from defects in material and workmanship. SIXNET's obligation under this warranty will be limited to repairing or replacing, at SIXNET's option, the defective parts within one year of the date of installation, or within 18 months of the date of shipment from the point of manufacture, whichever is sooner. Products may be returned by Buyer only after permission has been obtained from SIXNET. Buyer will prepay all freight charges to return any products to the repair facility designated by SIXNET. This limited warranty does not cover losses or damages which occur in shipment to or from Buyer or due to improper installation, maintenance, misuse, neglect or any cause other than ordinary commercial or industrial applications. In particular, SIXNET makes no warranties whatsoever with respect to implied warranties of merchantability or fitness for any particular purpose. All such warranties are hereby expressly disclaimed. No oral or written information or advice given by SIXNET or SIXNET's representative shall create a warranty or in any way increase the scope of this warranty. This limited warranty is in lieu of all other warranties whether oral or written, expressed or implied. SIXNET's liability shall not exceed the price of the individual units, which are the basis of the claim. In no event shall SIXNET be liable for any loss of profits, loss of use of facilities or equipment, or other indirect, incidental or consequential damages.

**INSTALLATION AND HAZARDOUS AREA WARNINGS** - These products should not be used to replace proper safety interlocking. No software-based device (or any other solid-state device) should ever be designed to be responsible for the maintenance of consequential equipment or personnel safety. In particular, SIXNET disclaims any responsibility for damages, either direct or consequential, that result from the use of this equipment in any application. All power, input and output (I/O) wiring must be in accordance with Class I, Division 2 wiring methods and in accordance with the authority having jurisdiction.

**WARNING**                      SUBSTITUTION OF COMPONENTS MAY IMPAIR SUITABILITY FOR CLASS 1,  
**(EXPLOSION HAZARD)**        DIVISION 2 (ZONE 2).

**WARNING**                      WHEN IN HAZARDOUS LOCATIONS, DISCONNECT POWER BEFORE  
**(EXPLOSION HAZARD)**        REPLACING OR WIRING UNITS.

**WARNING**                      DO NOT DISCONNECT EQUIPMENT UNLESS POWER HAS BEEN SWITCHED  
**(EXPLOSION HAZARD)**        OFF OR THE AREA IS KNOWN TO BE NONHAZARDOUS.

**FCC Statement** - This equipment has been tested and found to comply with the limits for a Class B digital device, pursuant to Part 15 of the FCC Rules. These limits are designed to provide reasonable protection against harmful interference in a residential installation. This equipment generates, uses and can radiate radio frequency energy and, if not installed and used in accordance with the instructions, may cause harmful interference to radio communications. However, there is no guarantee that interference will not occur in a particular installation. If this equipment does cause harmful interference to radio or television reception, which can be determined by turning the equipment off and on, the user is encouraged to try to correct the interference by one or more of the following measures: Reorient or relocate the receiving antenna; Increase the separation between the equipment and receiver; Connect the equipment into an outlet on a circuit different from that to which the receiver is connected; Consult the dealer or an experienced radio/TV technician for help.

**Copyright & Trademarks** - *Etherbus*<sup>®</sup> is a registered trademark of SIXNET, LLC. Copyright ©2007 SIXNET, LLC. All Rights Reserved.

**Note: All information in this document is subject to change without notice.**

# Section 1

## Overview

# General Information

This manual will help you install and maintain these Ethernet industrial Power over Ethernet (PoE) devices. These devices support standard IEEE 802.3af Power over Ethernet (PoE) and will work with any device that also supports this standard. Installation of the Ethernet devices is very easy and they will begin to operate as soon as they are powered up. For all models there are no user settings so they are truly plug and play.

The following products are covered by this manual:

Model	Type	Power In	Power Out	PSE Ports	PD Ports
EB-5ES-PSE-#	Switch	48 VDC	48V PoE	4	-
EB-PSE-48V-2	Injector	48 VDC	48V PoE	2	-
EB-PSE-24V-1	Injector	24 VDC	48V PoE	1	-
EB-PD-24V-1	Splitter	48V PoE	24 VDC	-	1
EB-PD-UPS-1	Splitter	48V PoE	14 VDC	-	1
EB-PS-4824-13	Converter	48 VDC	24 VDC	-	-

### Key:

PD = Powered Device (accepts 48V PoE power)

PSE = Power Sourcing Equipment (puts out 48V PoE power)

## Reference Images

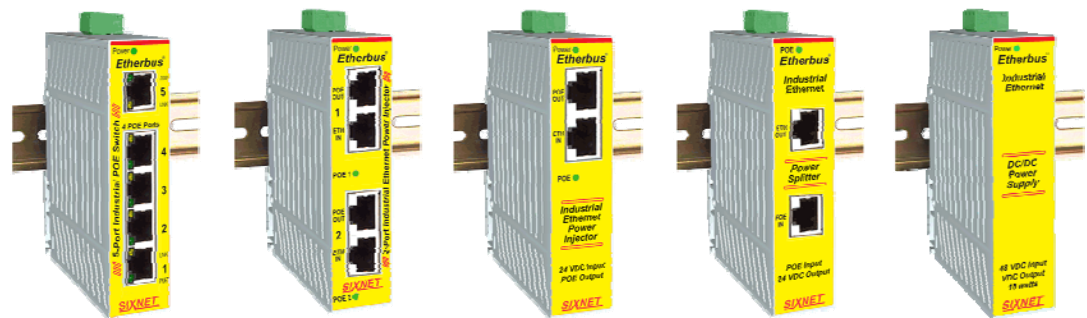

EB-5ES-PSE-1    EB-PSE-48V-2    EB-PSE-24V-1    EB-PD-24V-1    EB-PS-4824-13

## Safety Standards



These industrial Ethernet devices meet the following standards plus others:

**Electrical safety** – UL 508, CSA C22; EN61010-1 (IEC1010)

**Emissions** – FCC part 15, ICES 003, EN55022; Class B

**Immunity** – IEC61326-1

**Hazardous locations** – UL 1604, CSA C22.2/213 (Class 1, Div. 2), Groups A, B, C, D; Cenelec EN50021 and ATEX (Zone 2)

**Install the Managed Switches in accordance with local and national electrical codes.**

**Lightning Danger: Do not work on equipment during periods of lightning activity.**

**Do not connect a telephone line into one of the Ethernet RJ45 connectors.**

## Section 2

## LED Indicators

### Overview

The Etherbus devices have several LEDs to indicate the power and operational status of the unit. See below for the location of these LEDs and an explanation of their operation.

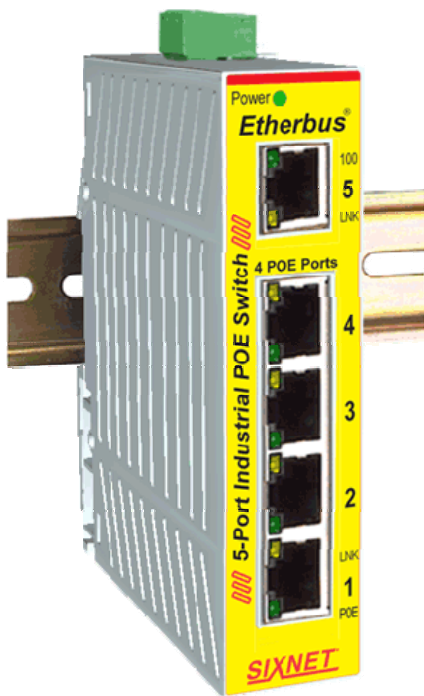

EB-5ES-PSE-1

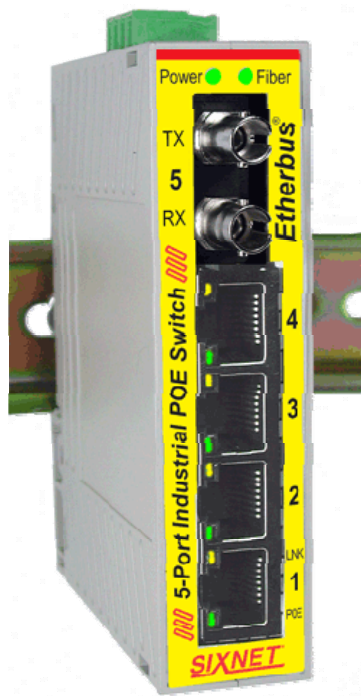

EB-5ES-PSE-2ST

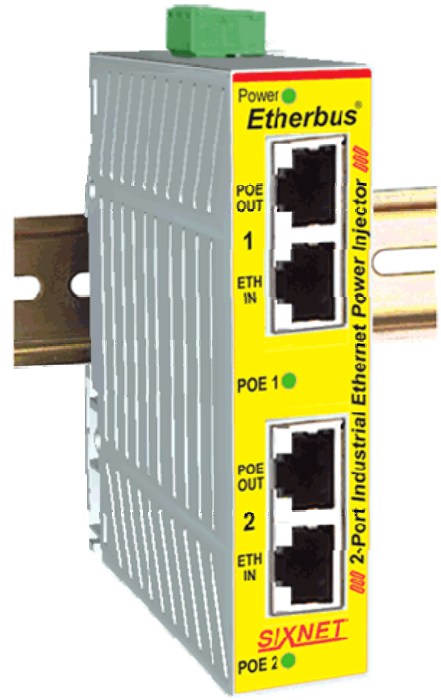

EB-PSE-48V-2



EB-PSE-24V-1

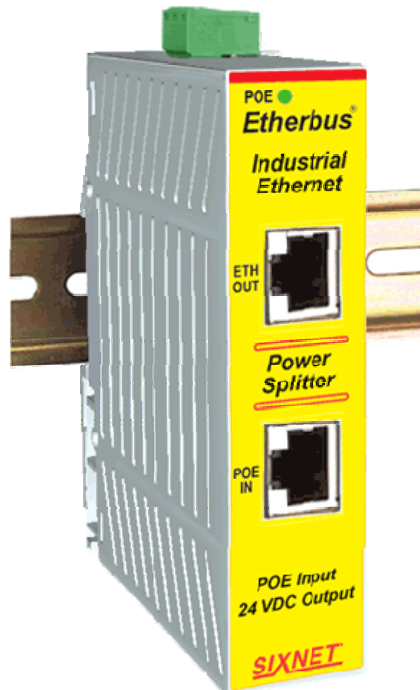

EB-PD-24V-1

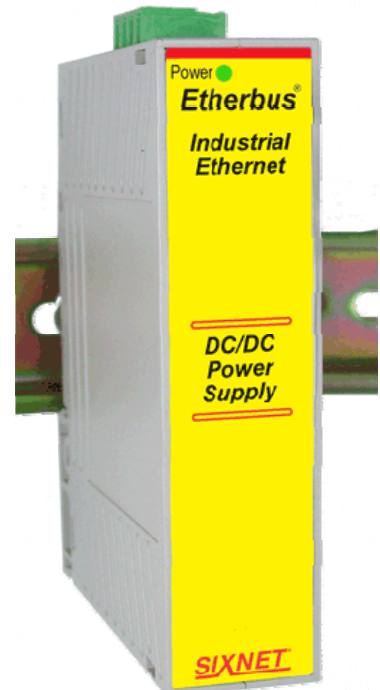

EB-PS-4824-13

### Typical LED Location for Etherbus Products

(Note: The LED locations may vary slightly from these images.)

## Power LED

On all models (except the splitter) there is one power LED that is ON if either power input (P1 or P2) has valid power applied to it. If the power LED is OFF then no power is being applied to the unit.

On the splitter the power LED will be ON when PoE power is detected on the incoming Ethernet line. It will be OFF if no PoE power is detected.

## ACT / LNK LED

This is the **Yellow** LED in the RJ45 ports of the Etherbus switch model EB-5ES-PSE-#. It indicates the Link and Activity status of the port.

<b>ON (yellow) (not flashing)</b>	Indicates that there <u>is</u> a proper Ethernet connection (Link) between the port and another Ethernet device, but no communications activity is detected.
<b>ON (yellow) (flashing)</b>	Indicates that there <u>is</u> a proper Ethernet connection (Link) between the port and another Ethernet device, and that there is communications activity.
<b>OFF</b>	Indicates that there <u>is not</u> a proper Ethernet connection (Link) between the port and another Ethernet device. Make sure the cable has been plugged securely into the ports at both ends.

## Speed 10/100 LED

This is the **Green** LED in the RJ45 connector of Port 5 on the Etherbus switch model EB-5ES-PSE-1. It indicates the Speed of the uplink port.

<b>ON (green)</b>	A 100 Mbps (100BaseT) connection is detected.
<b>OFF</b>	A 10 Mbps (10BaseT) connection is detected.

## Fiber Optic Port LED

This is the **Green** LED above the fiber port on the Etherbus switch model EB-5ES-PSE-2 or -3. It indicates the Link status of the fiber optic port.

<b>ON (green)</b>	A 100 Mbps (100BaseF) connection is detected.
<b>OFF</b>	No fiber connection is detected.

## PoE LED

This is the **Green** LED that is either integrated into the RJ45 port (on switch models) or is below the PoE ports (on injector models). It indicates the PoE status of the port.

<b>ON (green)</b>	A valid Powered Device (PD) is detected and the switch or injector is sourcing power on this port.
<b>OFF</b>	No valid Powered Device (PD) is detected so no power is being sourced.
<b>Periodically Blinks ON</b>	No valid Powered Device (PD) is detected or the connected device is drawing too little current (<10 mA) so no power is being sourced. However, the switch or injector is periodically looking for a valid device. This condition may occur when you have connected a PoE splitter but it has not been connected to a load yet. Once the connected device (such as a splitter) is loaded and draws more than 10 or 15 mA then power will be sourced.
<b>Error Code Blink</b>	Some models may blink an error code. If you see the same sequence of blinks repeatedly then contact SIXNET for more information.



## Section 3

## Installation

### Overview

These industrial Ethernet PoE devices can be snapped onto a standard DIN rail (EN50022) or screwed directly to a flat panel. Refer to the mechanical drawings below to properly mount your switch.

**Note:** Make sure to allow enough room to route your Ethernet copper or fiber optic cables.

### DIN Rail Mounting

#### Recommended DIN rail mounting steps:

1. Hook top back of unit over the din rail.
2. Push bottom back onto the din rail until it snaps into place.

#### Recommended DIN rail removal steps:

- A. Insert screwdriver into din clip and pry until it releases from the din rail.
- B. Unhook top of unit from din rail.

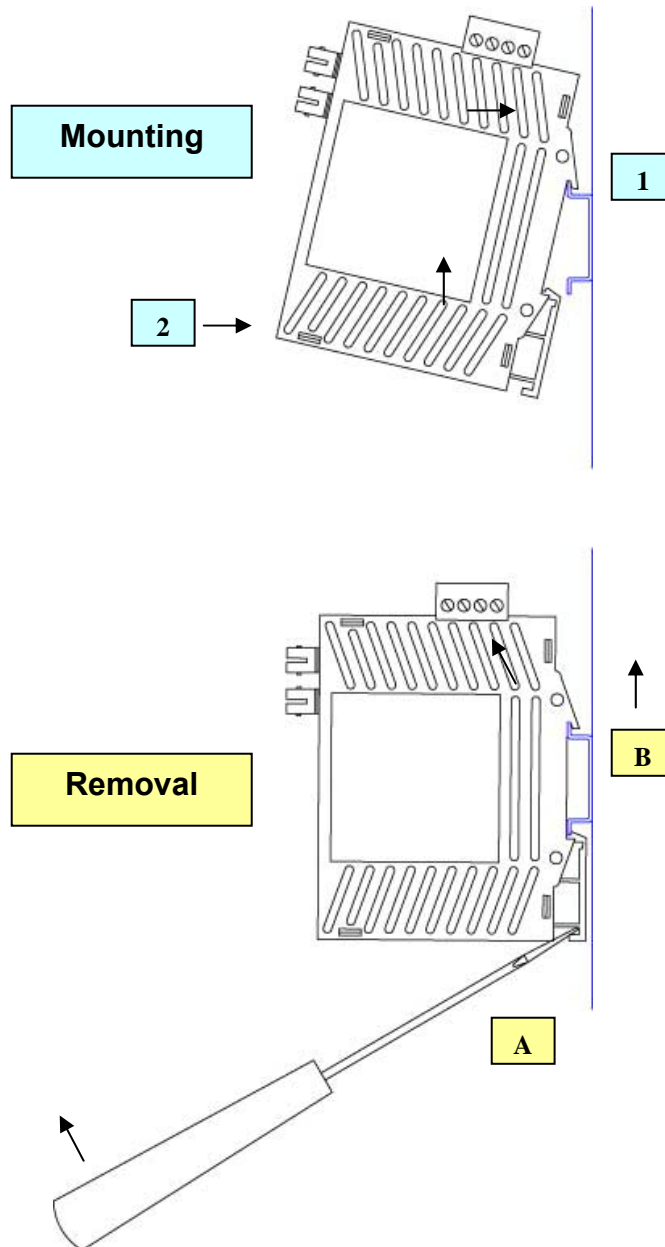

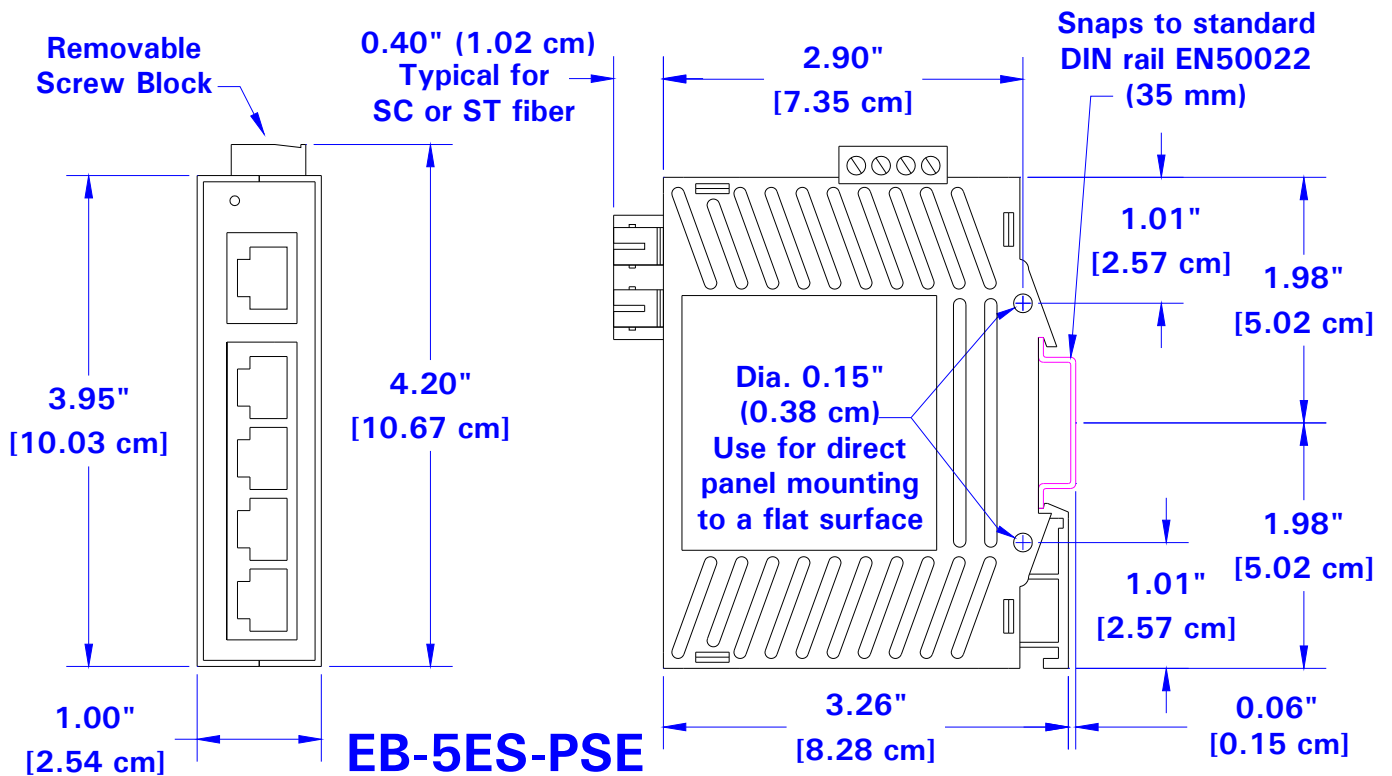

### Mechanical Dimensions for the Etherbus Switch

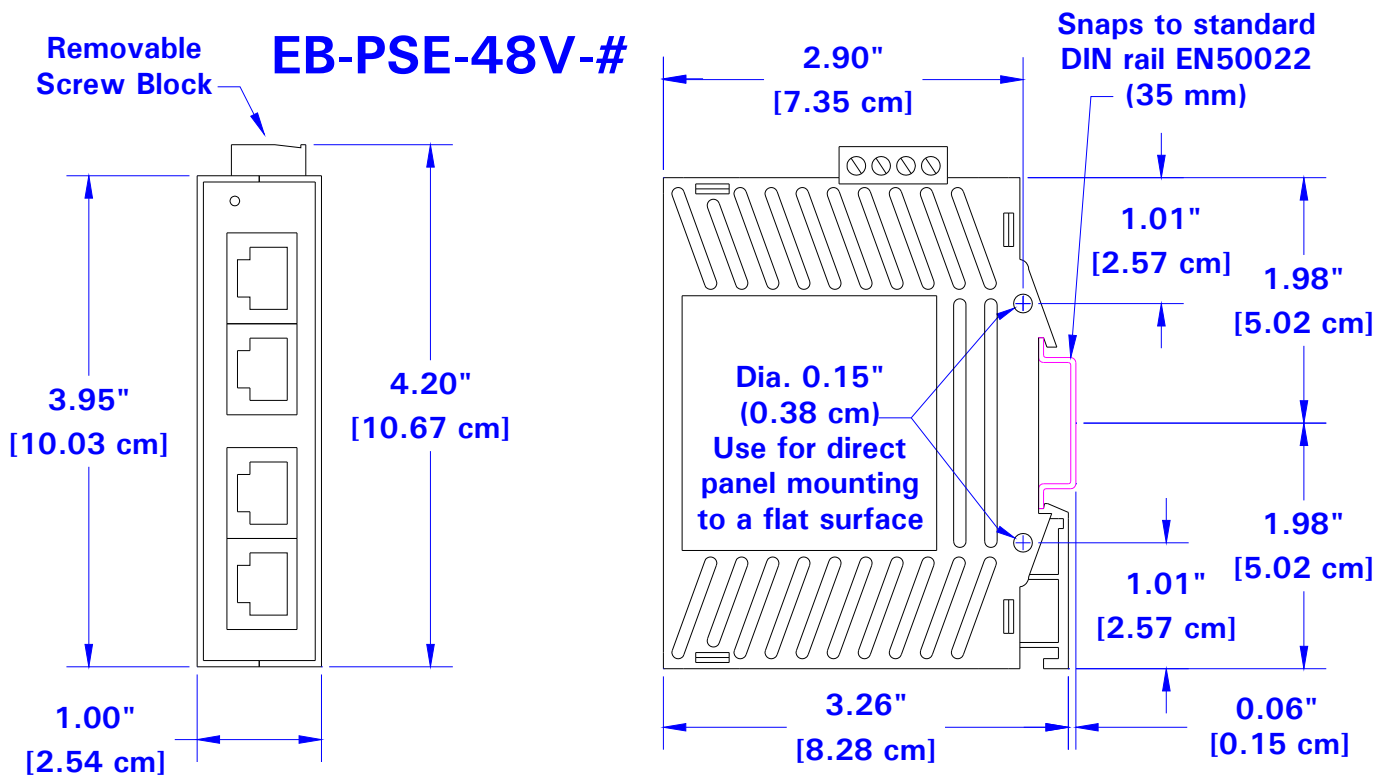

### Mechanical Dimensions for the Etherbus Dual Injector

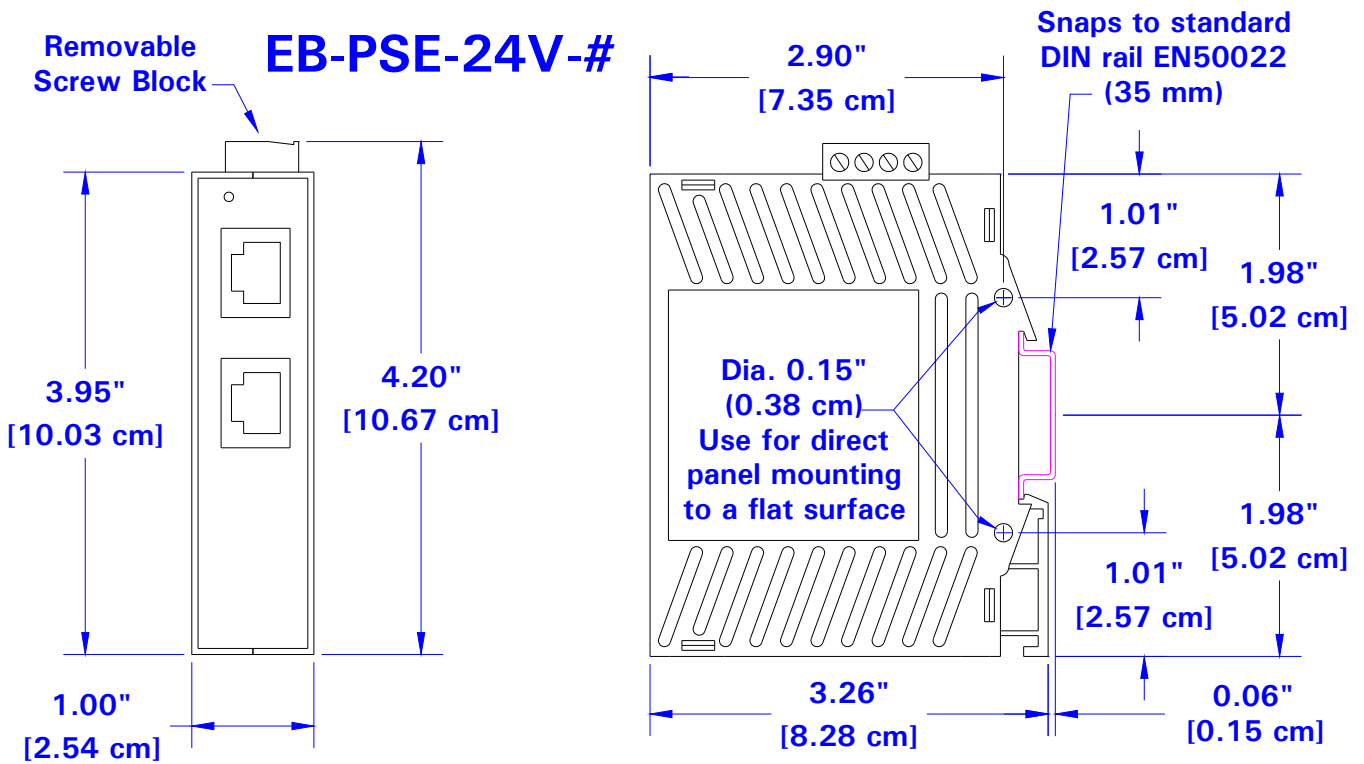

**Mechanical Dimensions for the Etherbus Injector with DC/DC Converter**

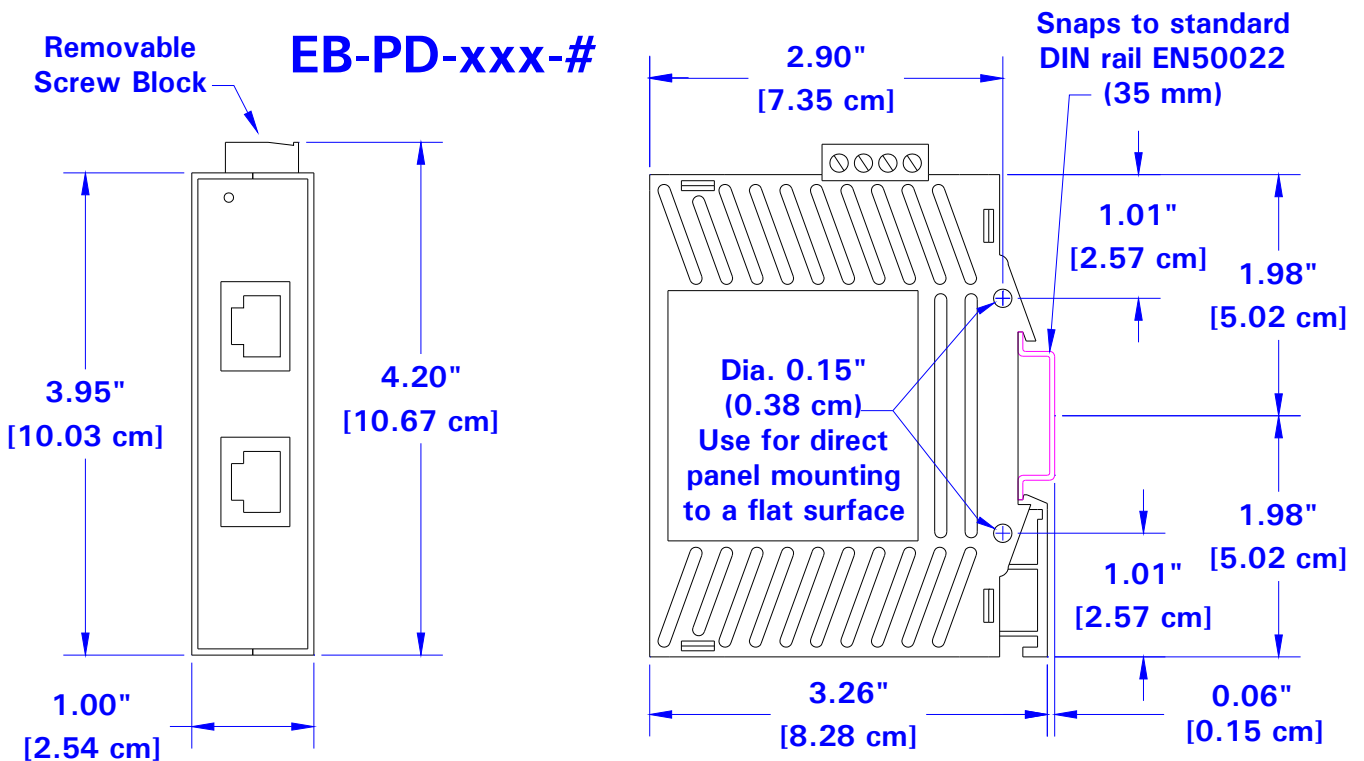

**Mechanical Dimensions for the Etherbus Splitter**



# EB-PS-4824-13

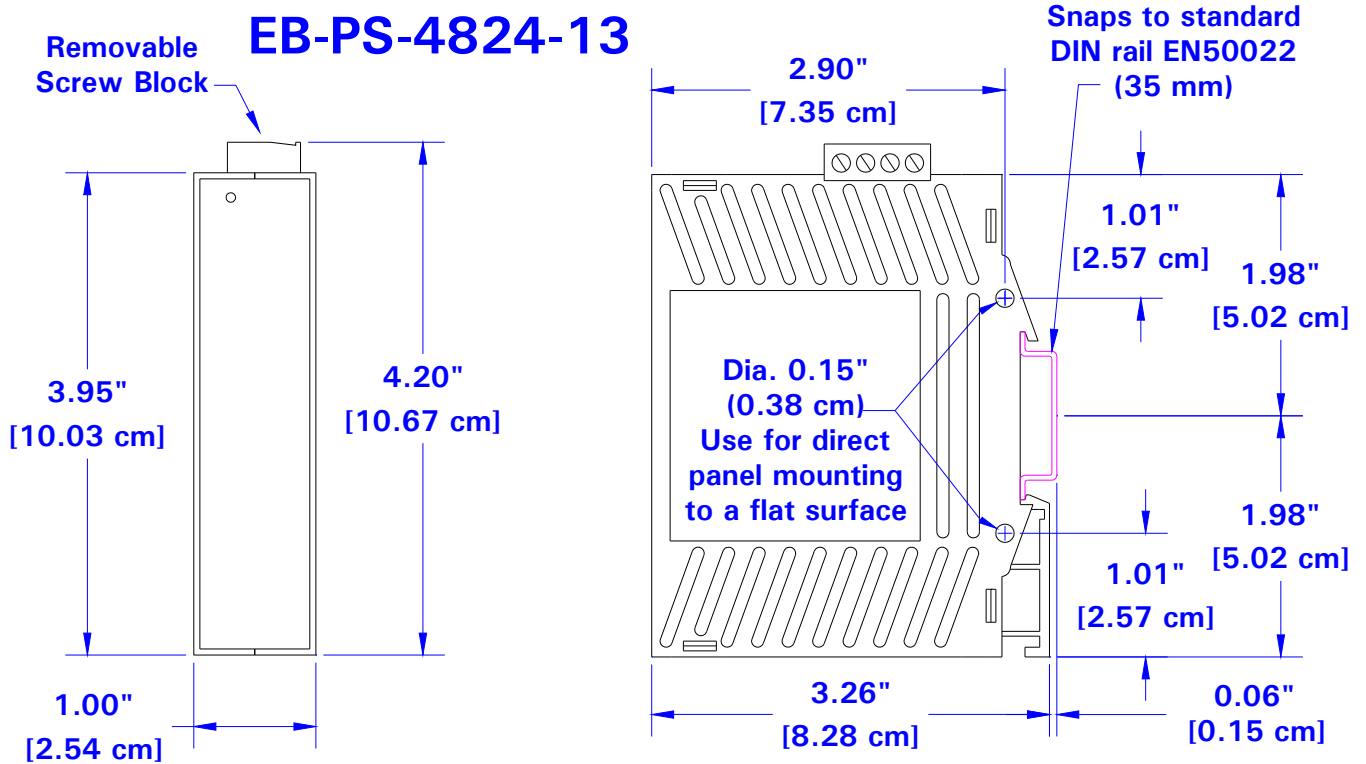

**Mechanical Dimensions for the Etherbus DC/DC Converter**

## Section 4

## Power Wiring

### Overview

These industrial Ethernet devices can be powered from the same DC source (typically 24 VDC or 48 VDC) that is used to power your other devices. Refer to the details below on how to properly wire power to or from your Etherbus devices.

### Screw Torque

When tightening the screws be careful to tighten to a maximum torque of 3.48 lb-in.

### Switch Power

The Etherbus switch accepts power in the range of 10 to 56 VDC (48 VDC nominal) and can source 48 VDC power to four PoE devices. For PoE sourcing (PSE) operation, the power must be in the range of 45 to 56 VDC. Otherwise, the switch will function properly as an industrial Ethernet switch but will not source any PoE power. For PoE operation, make sure your 48 VDC supply is rated for at least 16 Watts per PoE channel being sourced, plus some overhead for the switch. It is recommended that a supply with 75 Watts or more of power be used. The Etherbus switch supports dual power inputs allowing you to connect a backup power source. The backup power should have the same voltage as the primary power. Make your power connections as shown in the diagram below.

The PoE ports when sourcing power will put out 48 VDC\* (see note below) over the signal pair of the RJ45 connection:

- V+ on RX lines 1 and 2
- V- on TX lines 3 and 6
- Lines 4, 5, 7 and 8 are unused

### EB-5ES-PSE Single DC Power

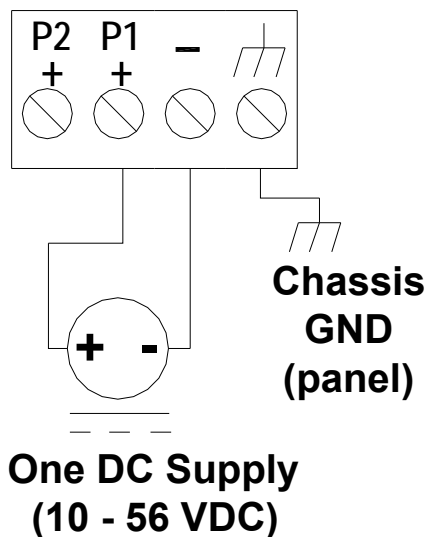

### EB-5ES-PSE Dual DC Power

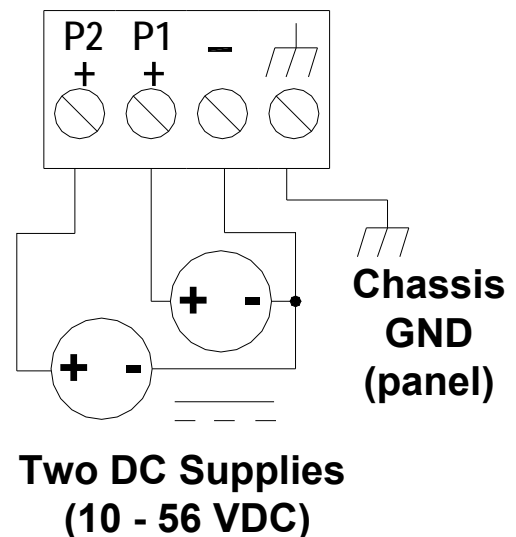

**\* Note:** When the supply voltage is 45 to 47 VDC then the power output for the PoE will be the same as the supply voltage. For example, if the supply voltage is 45 VDC then the PoE output will also be 45 VDC. If the supply voltage is 48 to 56 VDC then the PoE output will be regulated at 48 VDC.

## Dual Injector Power

The Ethernet Dual Injector accepts power in the range of 45 to 56 VDC (48 VDC nominal) and can source 48 VDC power to two PoE devices. Make sure your 48 VDC supply is rated for at least 16 Watts per PoE channel being sourced. Make your power connections as shown in the diagram below.

There are two models of this injector:

The standard -2A model when sourcing PoE power will put out 48 VDC\* (see note below) over the unused pair of lines in the RJ45 connection:

- V+ on lines 4 and 5
- V- on lines 7 and 8
- TX on lines 3 and 6
- RX on lines 1 and 2

The -2B model (special order) when sourcing PoE power will put out 48 VDC\* (see note below) over the signal pair of lines in the RJ45 connection:

- V+ on RX lines 1 and 2
- V- on TX lines 3 and 6
- Lines 4, 5, 7 and 8 are unused

### EB-PSE-48V DC Power Input

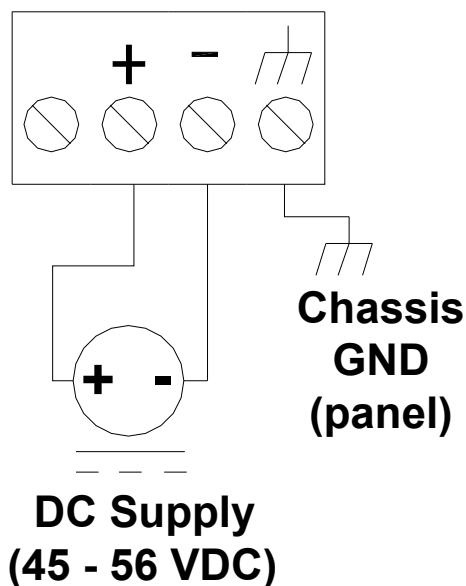

**\* Note:** When the supply voltage is 45 to 47 VDC then the power output for the PoE will be the same as the supply voltage. For example, if the supply voltage is 45 VDC then the PoE output will also be 45 VDC. If the supply voltage is 48 to 56 VDC then the PoE output will be regulated at 48 VDC.

## Single Injector Power

The Etherbus Single Injector has a built-in DC to DC converter allowing it to accept power in the range of 18 to 30 VDC (24 VDC nominal) and source 48 VDC power to one PoE device. Make sure your 24 VDC supply is rated for at least 20W. Make your power connections as shown in the diagram below.

There are two models of this injector:

The standard -1A model when sourcing PoE power will put out 48 VDC over the unused pair of lines in the RJ45 connection:

- V+ on lines 4 and 5
- V- on lines 7 and 8
- TX on lines 3 and 6
- RX on lines 1 and 2

The -1B model (special order) when sourcing PoE power will put out 48 VDC over the signal pair of lines in the RJ45 connection:

- V+ on RX lines 1 and 2
- V- on TX lines 3 and 6
- Lines 4, 5, 7 and 8 are unused

### EB-PSE-24V Single DC Power

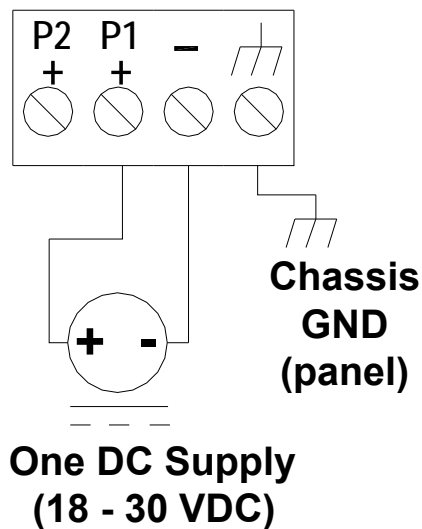

### EB-PSE-24V Dual DC Power

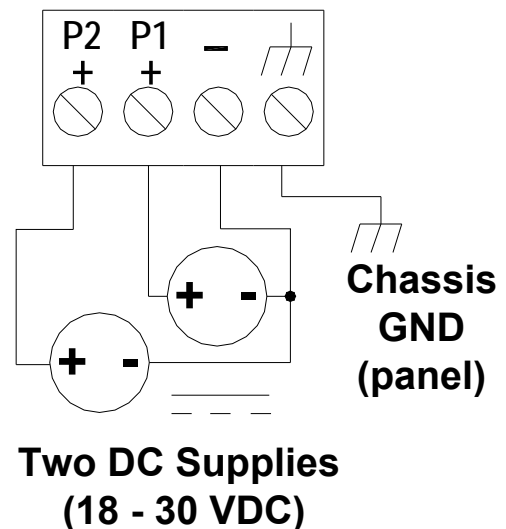

The Etherbus Splitter accepts 48 VDC from a PoE line and outputs an isolated and regulated 24 VDC @ 13 Watts to power your standard Ethernet (non-PoE) devices. Just connect your incoming PoE line (supports both power over the signals lines or power over the unused lines) to the PoE IN port. The splitter will convert the 48 VDC to 24 VDC and make it available on the pluggable screw terminal block. Make your power connections as shown in the diagram below.

### **EB-PD-24V DC Power Output**

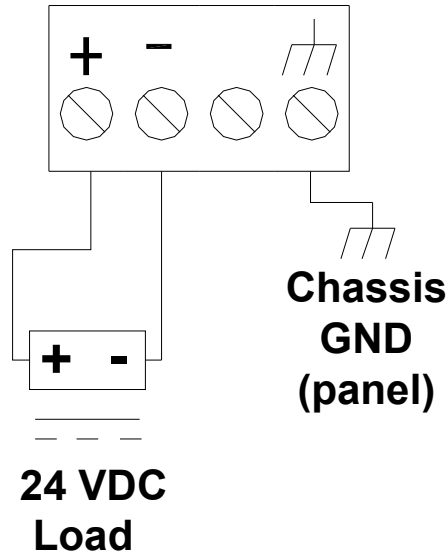

The -UPS model (special order) is the same as above but outputs 14 VDC instead of 24 VDC. The 14 VDC can be used to power 12V or 14V devices, and it can be used to charge a 12V seal-lead-acid battery for power backup. Make your power connections as shown in the diagram below.

### **EB-PD-UPS DC Power Output**

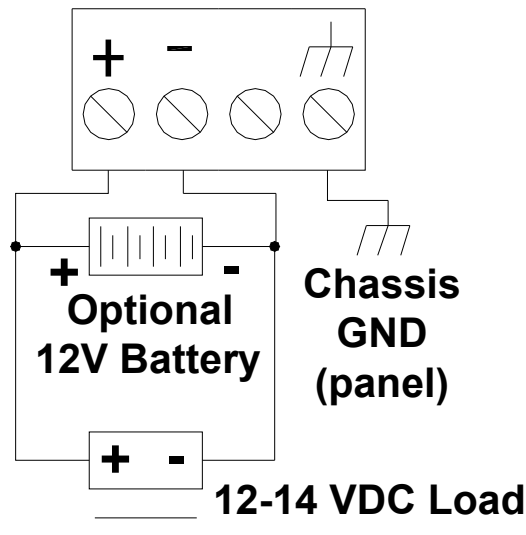

**DC/DC  
Converter  
Power**

The Etherbus DC to DC converter accepts power in the range of 45 to 56 VDC and outputs an isolated and regulated 24 VDC @ 13 watts. This convenient accessory allows you to power typical 24 VDC industrial devices from your 48 VDC system power. Make your input and output power connections as shown below.

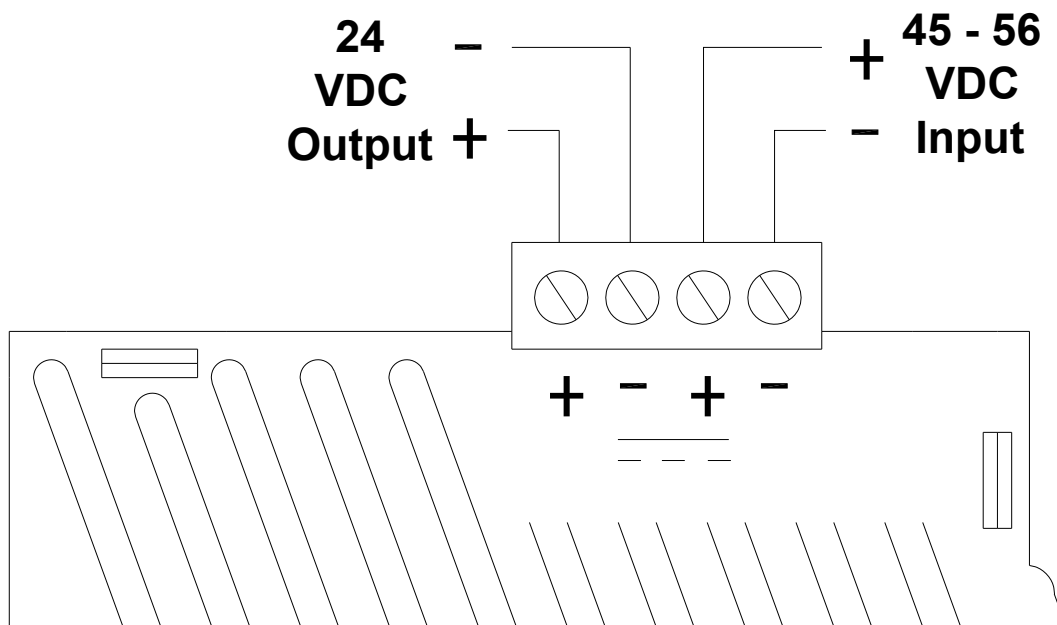

**EB-PS-4824-13 Power Connections**



# Section 5 Communication Wiring

## PoE Switch Operation

Unlike an Ethernet hub that broadcasts all messages out all ports, the Etherbus industrial Ethernet PoE switch will intelligently route Ethernet messages only out the appropriate port. The major benefits of this are increased bandwidth and speed, reduction or elimination of message collisions, and deterministic performance when tied with real-time systems.

The switch can support 10BaseT (10 Mbps) and 100BaseT (100 Mbps) on the RJ45 ports. Each of these ports will independently auto-sense the speed and duplex, allowing you to interface to fast (100 Mbps) Ethernet devices or legacy (10 Mbps). Optionally you can also have a 100BaseF (100 Mbps) fiber optic port.



## PoE Switch Overview

The Etherbus industrial Ethernet PoE switch provides connections to standard Ethernet devices such as PLCs, Ethernet I/O, industrial computers and much more. Two types of communication ports may be found on these switches: RJ45 (copper) Ethernet ports or fiber optic Ethernet ports.

## Switch RJ45 Port Wiring

Use data-quality (not voice-quality) twisted pair cable rated category 5 (or better) with standard RJ45 connectors. For best performance use shielded cable. Straight through or crossover RJ45 cable can be used regardless of the device the switch is to be connected to as all the ports are capable of auto-mdi/mdix-crossover detection.

The RJ45 Ethernet port connector bodies on these products are metallic and are connected to the Chassis GND terminal. Therefore, shielded cables may be used to provide further protection. To prevent ground loops, the cable shield should be tied to the metal connector body at one end of the cable only. Electrical isolation is also provided on the Ethernet ports for increased reliability.

**For Reference Only.  
Either cable wiring will work!**

Straight-thru Cable Wiring	
Pin 1	Pin 1
Pin 2	Pin 2
Pin 3	Pin 3
Pin 6	Pin 6

Cross-over Cable Wiring	
Pin 1	Pin 3
Pin 2	Pin 6
Pin 3	Pin 1
Pin 6	Pin 2

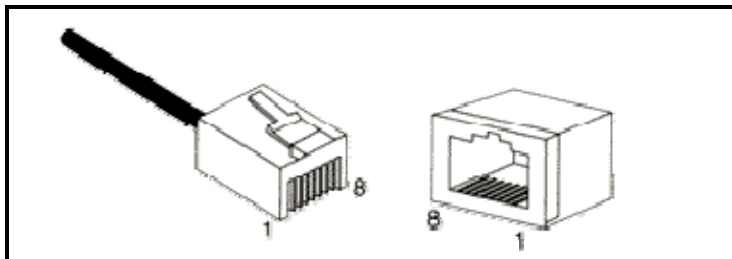

**Standard Ethernet Plug & Connector Pin Positions**

## RJ45 Cable Distance

The maximum cable length for 10/100/1000BaseT with Cat 5E twisted pair cables is typically 100 meters (328 ft.).

## Fiber Wiring Guidelines

The Etherbus industrial Ethernet PoE switch optionally has one 100 Mbps (100Base-FX) multimode or singlemode fiber ports. The maximum segment length is up to 120 km or more depending on the type of fiber optic transceiver installed in the switch. Refer to the technical specifications for details. Or contact SIXNET for the available fiber optic transceivers.

Each fiber optic port on the switch is comprised of a pair of SC or ST style connectors. For each fiber port there is a transmit (TX) and receive (RX) signal. When making your fiber optic connections, make sure that the transmit (TX) port of the switch connects to the receive (RX) port of the other device, and the receive (RX) port of the switch connects to the transmit (TX) port of the other device.

Use standard fiber optic wiring techniques (not covered by this manual) to make your connections. The corresponding ACT/LNK LED will be ON solid when you have made a proper connection. See images below for typical fiber optic port placement.

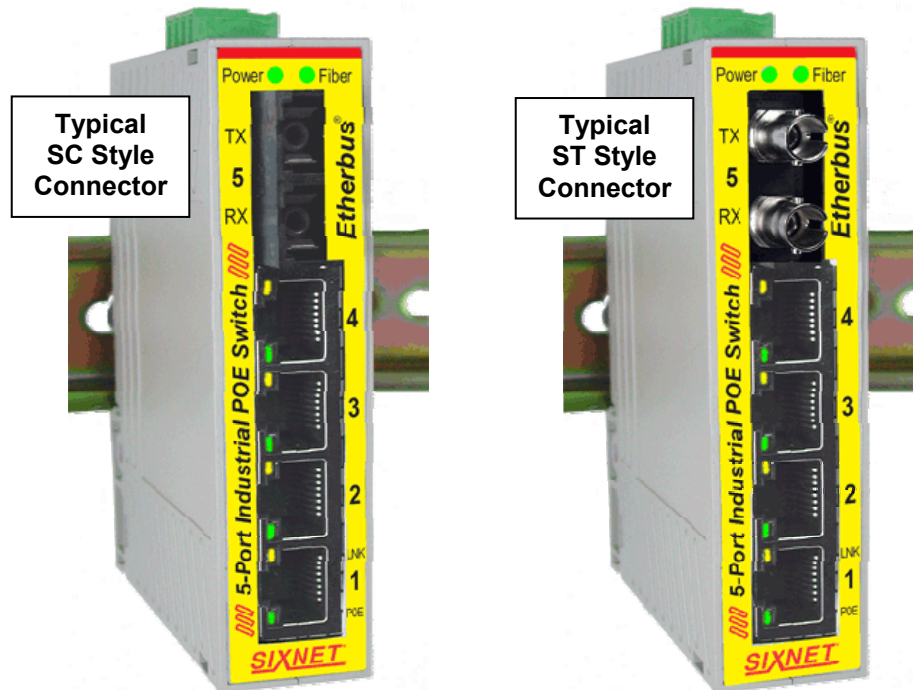

## Duplex Operation

The RJ45 ports will auto-sense for Full or Half duplex operation, while the fiber port is configured for full duplex operation. Note: Fiber devices with half duplex settings should still communicate with the switch. If otherwise then please contact SIXNET.

## Network Device Check

These industrial Ethernet switches are capable of supporting 10/100BaseT on the RJ45 (copper) ports and 100BaseF on the fiber optic ports. Make sure you connect the appropriate devices to each port.

## Verifying Connectivity

After all Ethernet and/or fiber connections are made, check the LED's corresponding to the ports that each of the devices are connected to. Ensure that for each port that is in use, the LED is on or blinking. If a port LED is off, go back and check for connectivity problems between that port and the network device connected.

## PoE Injector RJ45 Wiring

The Etherbus industrial Ethernet PoE injectors have two RJ45 connectors per PoE channel. See the diagram below. One RJ45 port is labeled as ETH IN (for Ethernet Input) and the other is Labeled as PoE OUT (for PoE Output). Connect your standard Ethernet (non-PoE) cable to the ETH IN port. This cable is typically coming from an Ethernet switch or router. Then connect the cable to be run to your PoE Powered device (PD) to the PoE OUT port. The PoE LED will be ON when power is being sourced to your device.



## PoE Splitter RJ45 Wiring

The Etherbus industrial Ethernet PoE splitter has two RJ45 ports. See the diagram below. One RJ45 port is labeled PoE IN (for PoE input) and the other is labeled ETH OUT (for Ethernet output). Connect the cable from your PoE (PSE) switch or injector to the PoE IN port. Then connect the cable to be run to your standard Ethernet (non-PoE) device to the ETH OUT port which does not have any power on it.

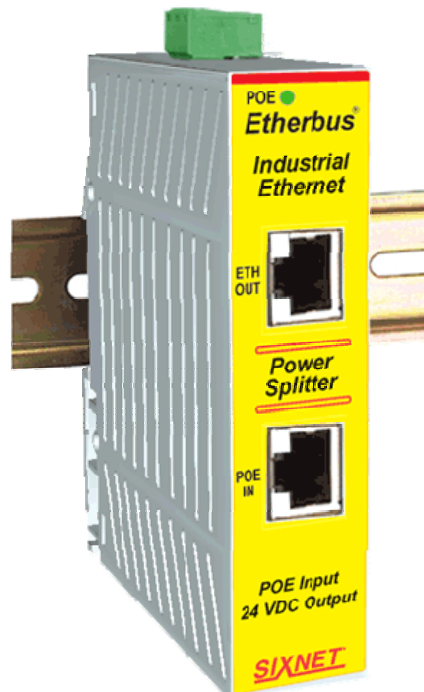

## Section 6

## Technical Specifications

### Technical Specs

Here are the hardware technical specifications for the products covered by this manual. Please contact SIXNET if additional information is required.

**All specifications are subject to change without notice.**

Ethernet Switch Performance Specifications	
Model	EB-5ES-PSE-#
<b>General</b>	Unmanaged, store & forward
Ethernet protocols supported	All IEEE 802.3
Ethernet switch ports	5 total with 4 PoE (PSE)
RJ45 ports (shielded)	10/100BaseTX
RJ45 speed (10 or 100 Mbps)	Auto-negotiation
RJ45 MDI/MDIX and TD/RD	Auto-crossover and auto-polarity
Ethernet isolation	1500 VRMS 1 minute
Fiber optic port speed / duplex	100BaseF (100 Mbps) / full duplex
Fiber optic port wavelength	1300 nm (others available)
Fiber multimode (mm) typical	50 or 62.5/125 um (SC or ST)
Fiber singlemode (sm) typical	9 or 10/125 um (SC or ST)
Fiber max. distance (full duplex) (see web for more details)	4 km (mm), 20 (sm) or 40 km (long haul) or more (contact SIXNET)
Typ. latency for 100 Mbps ports	5 us + frame time      Varies on load
MAC addresses and bandwidth	1024 and 3.2 Gbps
<b>Power In and PoE Out</b>	Redundant input terminals
Power input with reverse polarity protection	10-30 VDC with no PoE output 45-56 VDC for PoE output
Switch power consumption (typical all ports active at 100 Mbps)	2.0 W (5-port without fiber) + PoE 3.0 W (5-port with 1 fiber) + PoE
PoE power consumption	Up to 15.4 W per port
RJ45 pin assignments for PoE	TX/V- (3, 6); RX/V+ (1, 2)
Power input transient protection	15,000 watts peak
Power input spike Protection	5,000 watts (10 times for 10 uS)
PoE operation	Auto power management
PoE disconnect mode	DC disconnect
PoE auto-detection	Per IEEE 802.2af
PoE protection	Over-temperature, over-current, over/under-voltage and transient
<b>Environmental</b>	Truly industrial design
Operating temperature range	-40 to +75 °C (cold startup @ -40)
Storage temperature range	-40 to +85 °C
Humidity (non-condensing)	5 to 95% RH
Vibration, shock and freefall	IEC68-2-6, -27 and -32
Electrical safety	 UL508 / CSA C22.2/14 (CUL), EN61010-1 FCC Part 15 / ICES-003; EN55022 / IEC61326-1 UL1604 / CSA C22.2/213 (CUL), Class 1, Division 2; ATEX / Cenelec Zone 2
EMC emissions and immunity	
Hazardous locations	
Eye safety (fiber models)	IEC60825-1, Class 1; FDA 21
<b>Mechanical</b>	DIN rail or direct to panel mounting
Packaging material & protection	Polycarbonate with IP30 protection
Weight (approximate)	0.17 Kg (0.25 lbs)
Dimensions (H x W x D) (approximate)	4 x 1 x 3.3" (10 x 2.5 x 8.3 cm)
MTBF (estimated)	>1,000,000 hours

## Ethernet Injector Performance Specifications

Model	<b>EB-PSE-24V-1 or EB-PSE-48V-2</b>	
<b>General</b>	Industrial PoE Injectors	
Ethernet protocols supported	All IEEE 802.3	
Ethernet connectors per channel	2 (1 for Ethernet in, 1 for PoE out)	
Ethernet port standards	10/100BaseTX IEEE 802.3 / 802.3u	
<b>PoE Output</b>	Fully IEEE 802.2af compliant	
IEEE 802.3af PoE operation	Power Sourcing Equipment (PSE)	
PoE power output	48 VDC @ 15.4 Watts per channel (24V model only: derate 1W per 2°C after 60°C)	
RJ45 PoE pin assignments (A=unused pair; B=signal pair)	A: TX(3,6); RX(1,2); V-(7,8); V+(4,5) B: TX/V- (3, 6); RX/V+ (1, 2)	
PoE operation	Auto-detection & power management	
PoE disconnect mode	AC on 24V-1 and DC on 48V-2	
PoE protection	Over-temp, over-current, over/under-voltage & transient	
<b>Power Input</b>	Fully IEEE 802.3af PoE compliant	
Power input for 48V-2 models	45-56 VDC @ 31 Watts max.	
Power input for 24V-1 models	18-30 VDC @ 20 Watts max.	
PoE transient protection	15,000 watts peak	
PoE spike protection	5,000 watts (10 times for 10 uS)	
<b>Environmental</b>	Truly industrial design	
Operating temperature range	-40 to +75 °C (cold startup @ -40) (see PoE power derating above)	
Storage temperature range	-40 to +85 °C	
Humidity (non-condensing)	5 to 95% RH	
Vibration, shock and freefall	IEC68-2-6, -27 and -32	
Electrical safety		UL508 / CSA C22.2/14 (CUL), EN61010-1
EMC emissions and immunity		FCC Part 15 / ICES-003; EN55022 / IEC61326-1
Hazardous locations		UL1604 / CSA C22.2/213 (CUL), Class 1, Division 2; ATEX / Cenelec Zone 2
<b>Mechanical</b>	DIN rail or direct to panel mounting	
Packaging material and protection	Polycarbonate with IP30 protection	
Weight (approximate)	0.17 Kg (0.25 lbs)	
Dimensions (H x W x D) (approximate)	4 x 1 x 3.3" (10 x 2.5 x 8.3 cm)	
MTBF (estimated)	>1,000,000 hours	

## Ethernet Splitter Performance Specifications

Model	<b>EB-PD-24V-1</b>	
<b>General</b>	Industrial PoE Splitter	
Ethernet protocols supported	All IEEE 802.3	
Ethernet ports	2 (1 for PoE in, 1 for Ethernet out)	
Ethernet port standards	10/100BaseTX IEEE 802.3 / 802.3u	
<b>PoE Input</b>	Fully IEEE 802.3af PoE compliant	
IEEE 802.3af PoE operation	Powered Device (PD)	
PoE Power input range	45-56 VDC	
PoE power input	Automatic detection and classification (power is accepted on either the signal or unused pairs)	
PoE protection	Over/under voltage lockout and inrush control	
PoE transient protection	15,000 watts peak	
PoE spike protection	5,000 watts (10 times for 10 uS)	
<b>Power Output</b>	Isolated power	
Voltage output	24 VDC, 0.54 Amps (24V model) 14 VDC, 0.93 Amps (UPS model)	
Power output	13 watts	
<b>Environmental</b>	Truly industrial design	
Operating temperature range	-40 to +75 °C (cold startup @ -40)	
Storage temperature range	-40 to +85 °C	
Humidity (non-condensing)	5 to 95% RH	
Vibration, shock and freefall	IEC68-2-6, -27 and -32	
Electrical safety		UL508 / CSA C22.2/14 (CUL), EN61010-1
EMC emissions and immunity		FCC Part 15 / ICES-003; EN55022 / IEC61326-1
Hazardous locations		UL1604 / CSA C22.2/213 (CUL), Class 1, Division 2; ATEX / Cenelec Zone 2
<b>Mechanical</b>	DIN rail or direct to panel mounting	
Packaging material and protection	Polycarbonate with IP30 protection	
Weight (approximate)	0.17 Kg (0.25 lbs)	
Dimensions (H x W x D) (approximate)	4 x 1 x 3.3" (10 x 2.5 x 8.3 cm)	
MTBF (estimated)	>1,000,000 hours	



## Etherbus DC/DC Converter Performance Specifications

Model		<b>EB-PS-4824-13</b>	
Output	DC voltage	24 VDC	
	Rated current	0.54 Amps	
	Current range	0 – 0.54 Amps	
	Rated power	13 Watts	
	Ripple / noise (max.)	200 mV p-p	
	Voltage tolerance	+/- 1%	
	DC voltage range	45 – 56 VDC	
	Efficiency (typ.)	85 %	
Protection	Current (typ.)	0.32 Amps @ 48 VDC	
	Over-load	Current limiting with automatic recovery	
	Over-voltage	Transient: 15Kw peak; Surge: 5K watts (10x10 uS)	
Environmental	Over-temperature	140°C with auto. recovery	
	Operation temp.	-40 to + 75°C	
	Operation humidity	5 to 95% RH (non-cond.)	
	Storage	-40 to + 85°C	
Standards	Vibration, shock and freefall	IEC68-2-6, -27 and -32	
	Safety		UL508 / CSA C22.2/14 (CUL); EN61010-1
	Hazardous locations		UL1604 / CSA C22.2/213 (CUL), Class 1, Division 2; ATEX / Cenelec Zone 2
	EMC emissions and immunity	FCC Part 15 / ICES-003; EN55022 / IEC61326-1	
Miscellaneous	Withstand voltage	Input to output: 1500 Vrms	
	MTBF (estimated)	>1,000,000 hours	
	Packaging	Polycarbonate; IP30	
	Mounting	DIN rail or flat to panel	
	Weight (approximate)	0.17 Kg (0.25 lbs)	
	Dims (w x h x d) (approximate)	25 x 101 x 76 mm (1.0 x 4.0 x 3.0 inches)	

## Section 7

## Service Information

### Service Information

We sincerely hope that you never experience a problem with any **SIXNET** product. If you do need service, call **SIXNET** at (518) 877-5173 and ask for Applications Engineering. A trained specialist will help you to quickly determine the source of the problem. Many problems are easily resolved with a single phone call. If it is necessary to return a unit to us, an RMA (Return Material Authorization) number will be given to you.

**SIXNET** tracks the flow of returned material with our RMA system to ensure speedy service. You must include this RMA number on the outside of the box so that your return can be processed immediately.

The applications engineer you are speaking with will fill out an RMA request for you. If the unit has a serial number, we will not need detailed financial information. Otherwise, be sure to have your original purchase order number and date purchased available.

We suggest that you give us a repair purchase order number in case the repair is not covered under our warranty. You will not be billed if the repair is covered under warranty.

Please supply us with as many details about the problem as you can. The information you supply will be written on the RMA form and supplied to the repair department before your unit arrives. This helps us to provide you with the best service, in the fastest manner. Normally, repairs are completed in two days. Sometimes difficult problems take a little longer to solve.

If you need a quicker turnaround, ship the unit to us by air freight. We give priority service to equipment that arrives by overnight delivery. Many repairs received by mid-morning (typical overnight delivery) can be finished the same day and returned immediately.

We apologize for any inconvenience that the need for repair may cause you. We hope that our rapid service meets your needs. If you have any suggestions to help us improve our service, please give us a call. We appreciate your ideas and will respond to them.

#### For Your Convenience:

Please fill in the following and keep this manual with your **SIXNET** system for future reference:

P.O. #: \_\_\_\_\_ Date Purchased: \_\_\_\_\_

Purchased From: \_\_\_\_\_

### Product Support

To obtain support for SIXNET products:

**Latest product info:** <http://www.sixnet.com>

**Phone:** +1 (518) 877-5173

**Fax:** +1 (518) 877-8346

**E-mail:** [support@sixnet.com](mailto:support@sixnet.com)

**Address:** SIXNET Technology Park, 331 Ushers Road, Ballston Lake, NY 12019